

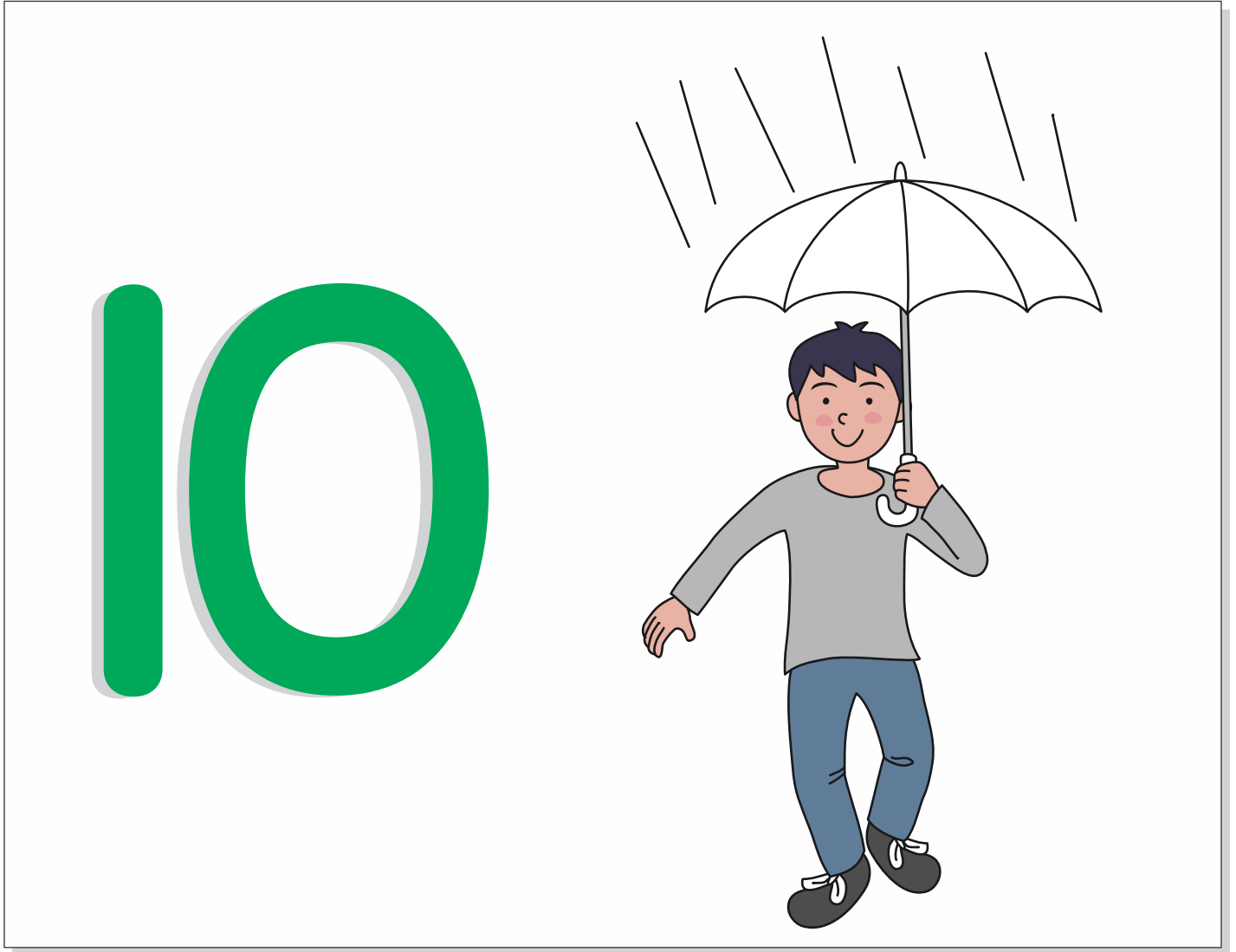

Student Name: _____ Date: _____

Cut the 10 raindrops with light blue paper and paste it under the umbrella.



Trace number 10:

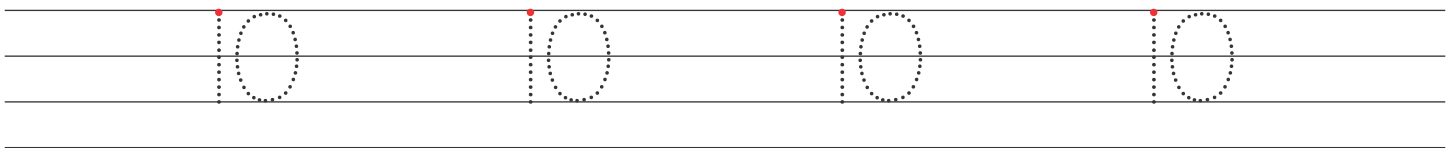



scan QR code for
more worksheets

Student Name: _____ Date: _____

Colour the leaves which contains number '10' and trace the number 10.

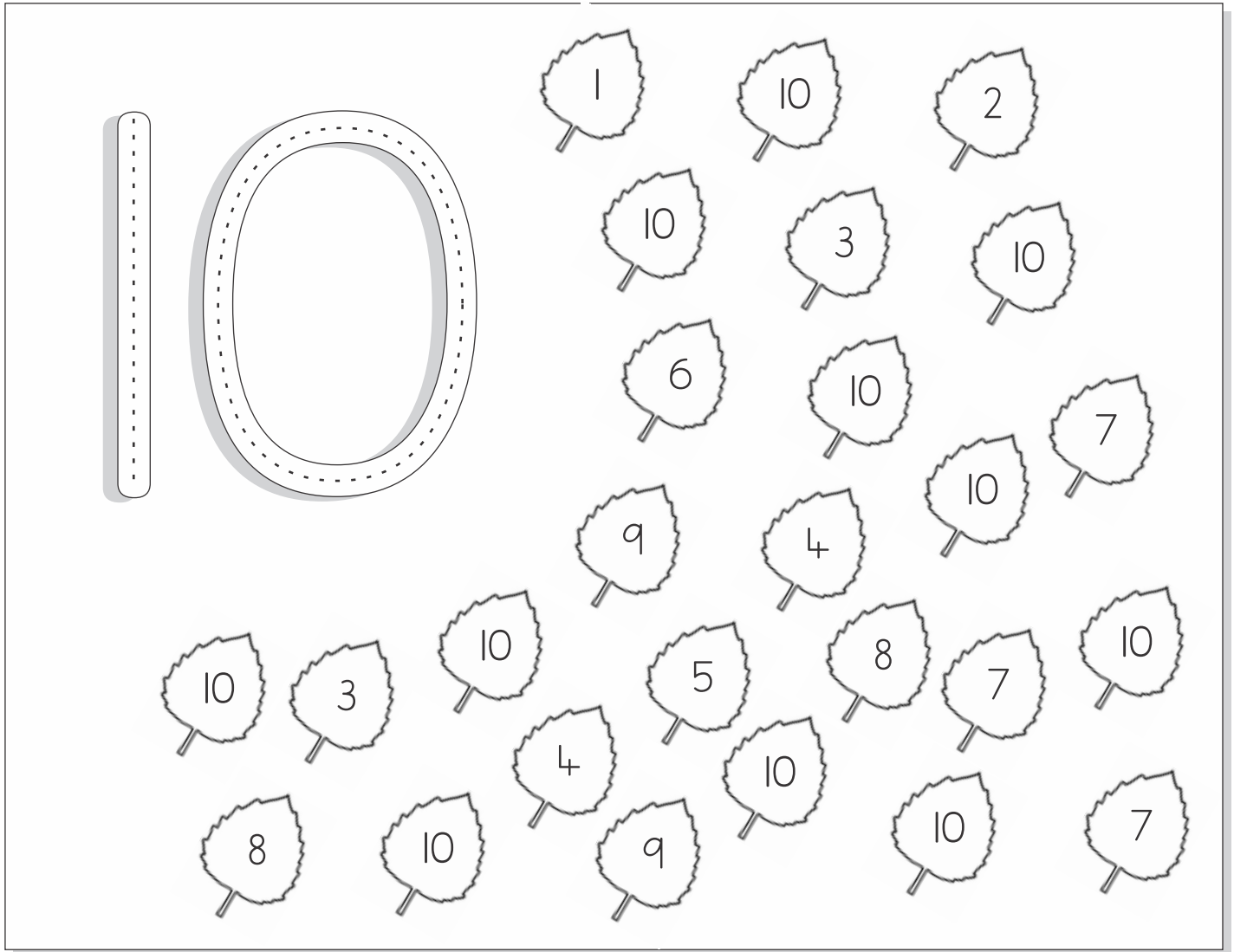

The activity area contains a large tracing guide for the number 10 on the left, consisting of a vertical bar and an oval shape, both with dashed lines for tracing. To the right of the tracing guide is a collection of 20 leaves, each with a number written on it. The numbers are: 1, 10, 2, 10, 3, 10, 6, 10, 7, 9, 4, 10, 10, 8, 7, 10, 3, 5, 8, 7, 10, 10, 4, 10, 7, 8, 10, 9, 10, 7.

Trace number 10:

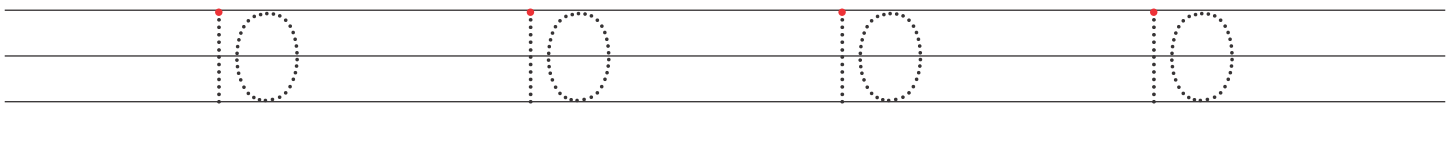

Four sets of horizontal lines for tracing the number 10. Each set consists of a top line, a middle line, and a bottom line. The number 10 is drawn with dashed lines between the middle and bottom lines, and a vertical dashed line from the top line to the middle line. A small red dot is placed at the top of the vertical line for each number.



scan QR code for
more worksheets

Student Name: _____ Date: _____

Colour the number '10' with the help of finger print.

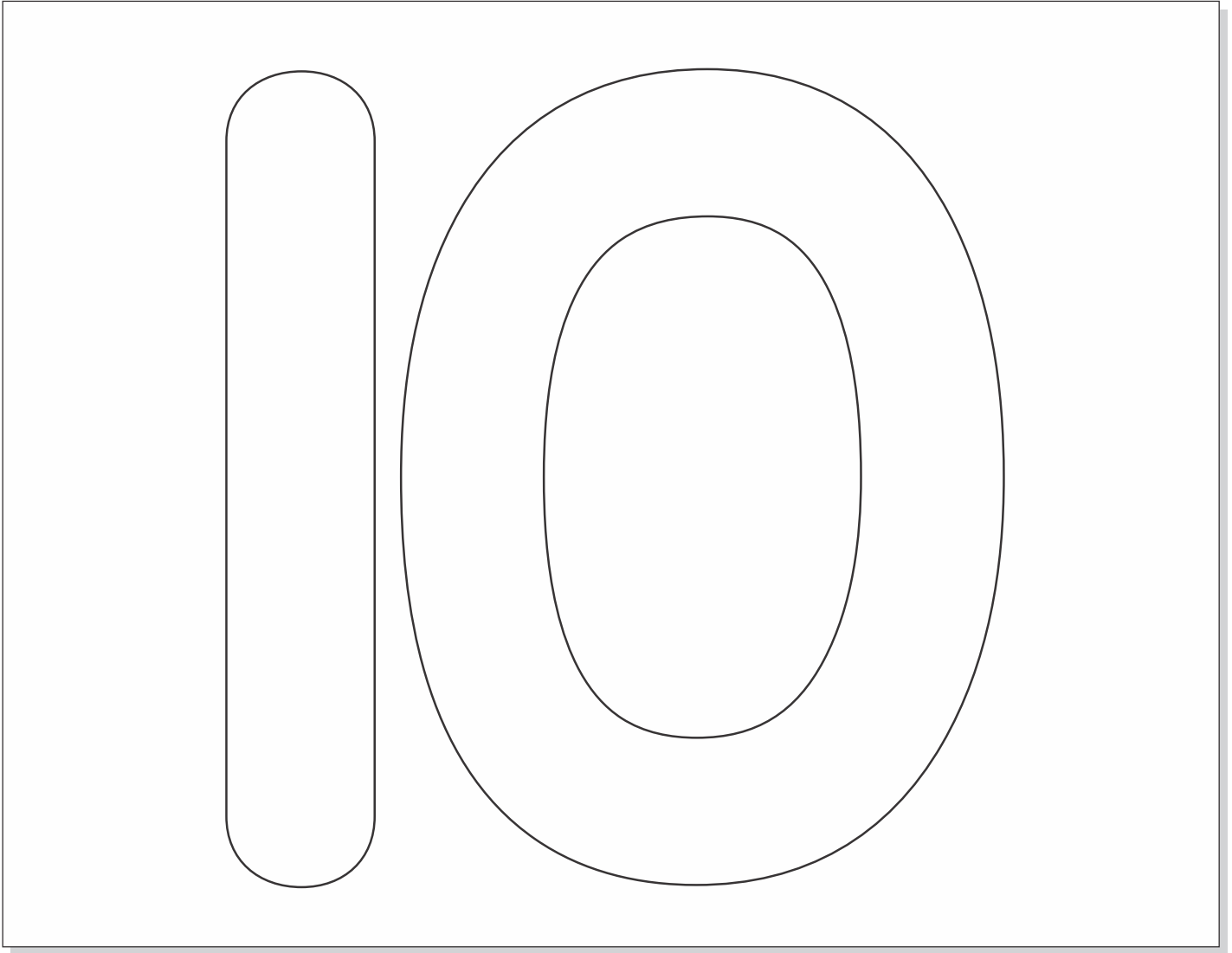

Trace number 10:

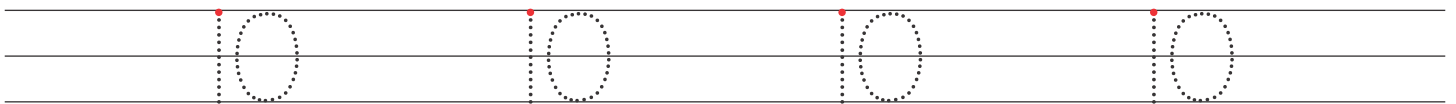



Student Name: _____ Date: _____

Trace the number 10 and colour the things which are '10'.

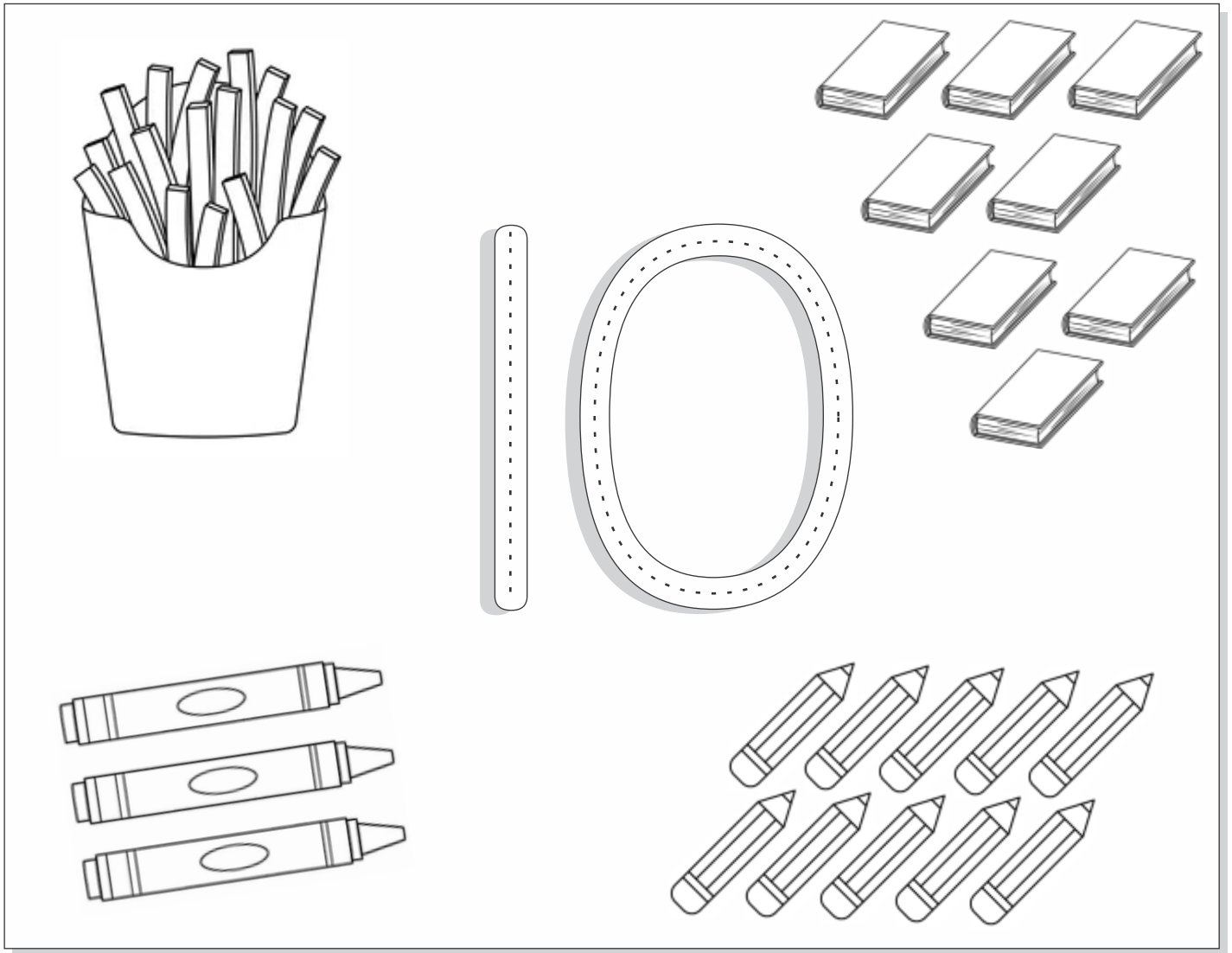

Trace number 10:

Tracing practice lines for the number 10. Each line consists of a top solid line, a middle dashed line, and a bottom solid line. The number 10 is shown as a dashed outline on each line, with a red dot at the top of the vertical stroke to indicate the starting point.



scan QR code for
more worksheets

Student Name: _____ Date: _____

Colour the mittons and trace the number '10'.

